

SCUBAPRO[®]

Technical Service Reference & Repair Guide

Contents:

Case Assembly	Figure #1
Downstream Valve	Figure #2
Dive Pre-Dive Assembly	Figure #3
Full Second Stage Cutaway	Figure #4
VIVA	Figure #5
Dive Pre-Dive Control	Figure #6
Features & Benefits Summary	Figure #6
Adjustment Procedures & Tips	Figure #7
Air On Adjustments	Figure #8
Magnehelic Checks	Figure #9
VIVA Checks	Figure #10
Trouble Shooting Guide	Figure #11

Polar Second Stage

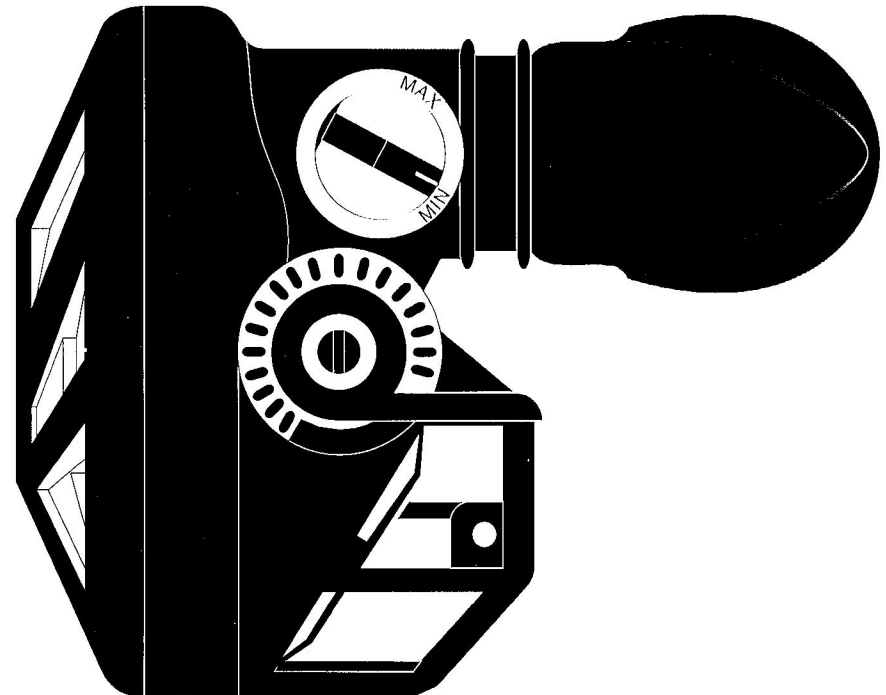

Important Note: The following information "is not" designed to be a complete training guide for infield servicing of the Polar second stage. All Scubapro technicians are required to attend an annual repair clinic to insure safe handling and servicing of Scubapro products.

Figure #1

SCUBAPRO[®] Polar Second Stage Case Assembly

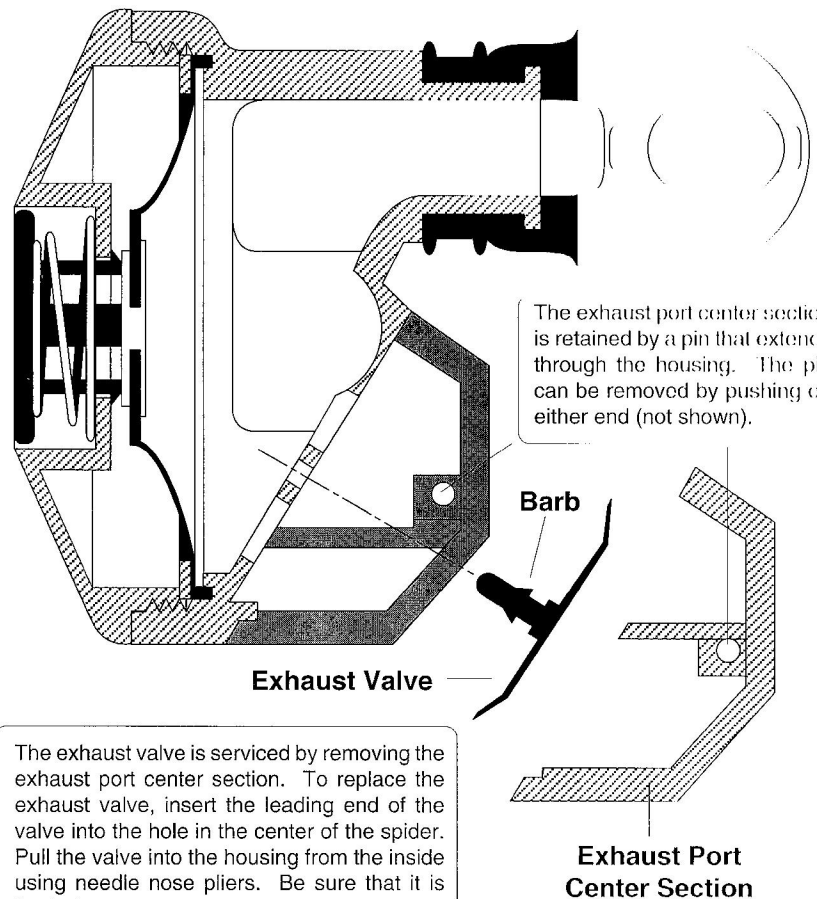
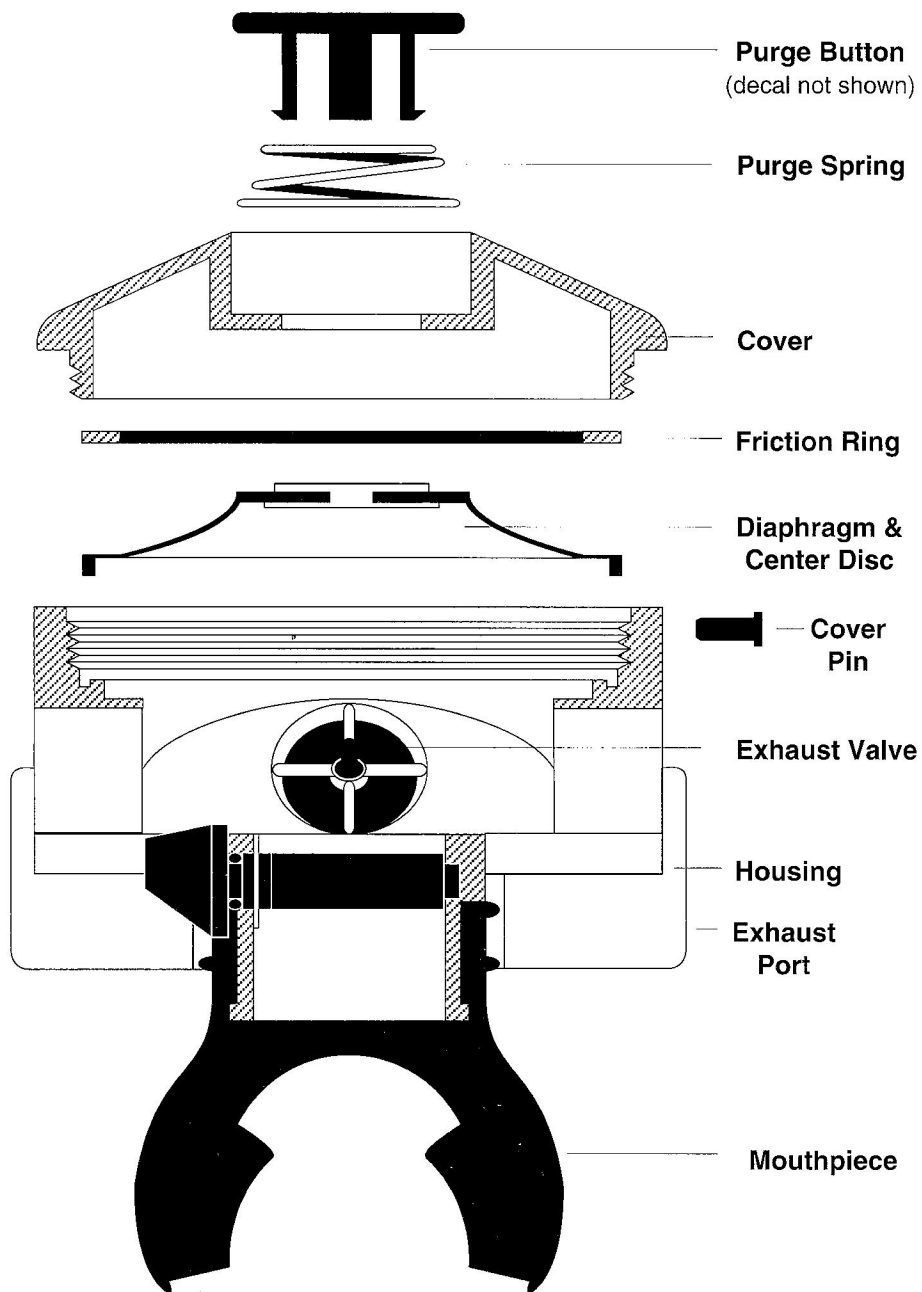

The exhaust valve is serviced by removing the exhaust port center section. To replace the exhaust valve, insert the leading end of the valve into the hole in the center of the spider. Pull the valve into the housing from the inside using needle nose pliers. Be sure that it is firmly in place with the molded barb indexed properly with the housing.

Figure #2

SCUBAPRO[®] Polar Second Stage Downstream Valve

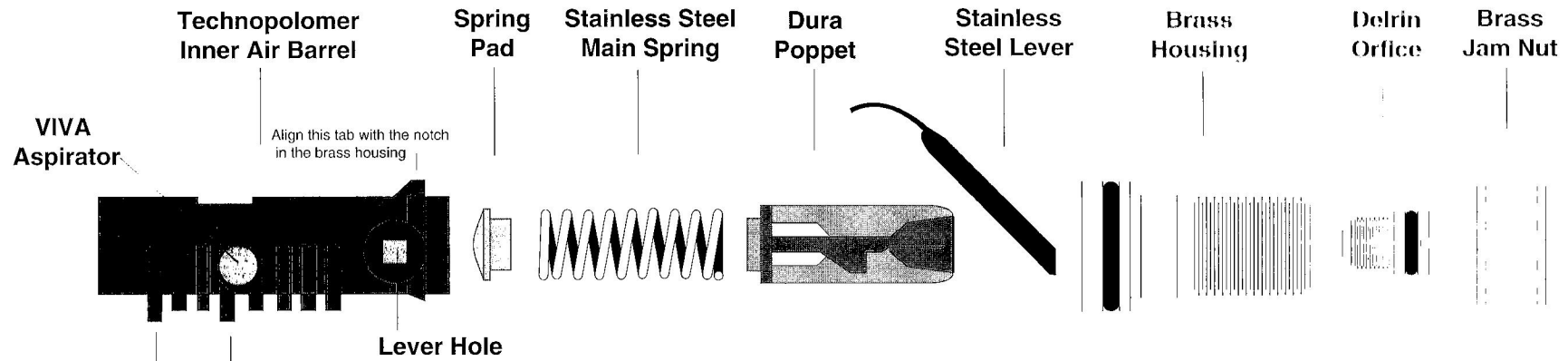

Important Note: The two extended posts on the bottom of the inner air barrel fit snugly into the molded cavities in the main regulator housing. Be sure to lift up on the inner air barrel before trying to slide it away from the brass housing.

Air Barrel Cutaway Assembly: The Scubapro Polar second stage utilizes high strength plastics in key components to retard ice build up. The poppet, inner air barrel, and orifice are all designed to repel ice particles and maintain free movement in all but very extreme conditions. The classic downstream valve is the essence of simplicity and dependability. The Dura poppet features a replaceable rubber seat, keeping repair costs at a minimum. The illustration below has been enlarged for close inspection. This valve mechanism is shown installed in the housing in figure #4.

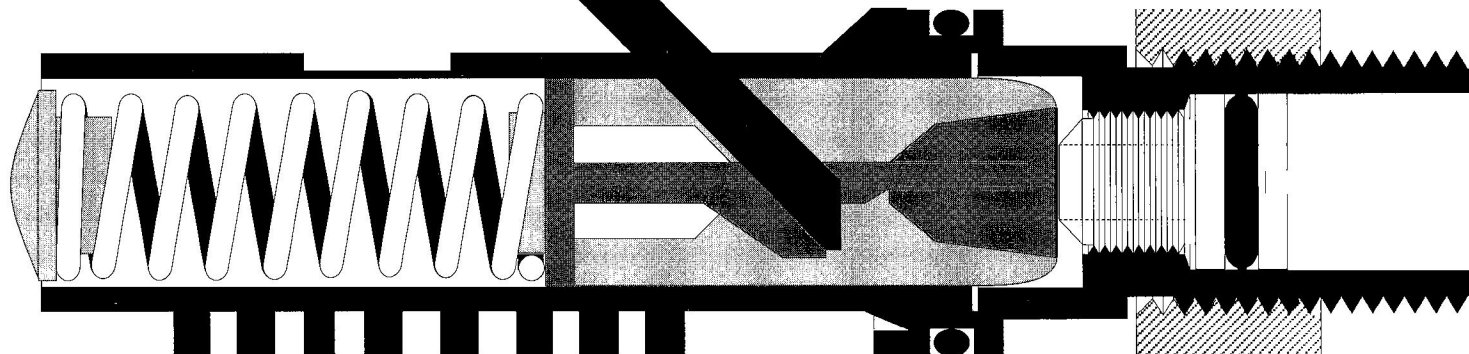
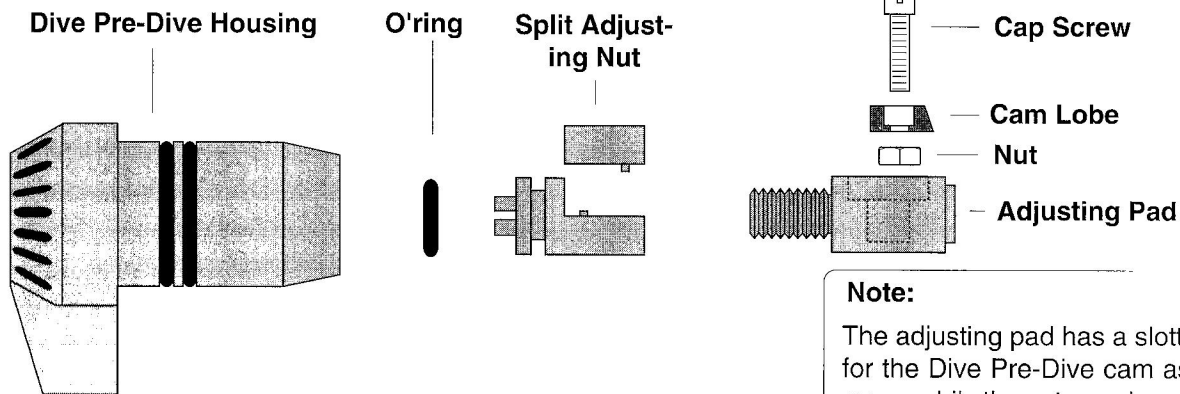

Figure #3

SCUBAPRO® Polar Second Stage Dive Pre-Dive Assy.



Note:

The adjusting pad has a slotted cavity to accommodate the anchor nut for the Dive Pre-Dive cam assembly. This allows the adjusting pad to move while the nut remains stationary. When the housing is rotated, the cam lobe tracks along the inside edge of the main regulator housing causing the entire assembly to move in and out. This action dramatically increases spring tension in the Pre-Dive position.

Note:

The enlarged cutaway detail to the right shows how the external adjustment feature of the Polar works. When the split adjusting nut is turned clockwise, via the screwdriver slot, spring tension is reduced. Turning the nut counterclockwise increases spring tension. This feature allows the inhalation effort to be adjusted without altering lever height. The screwdriver slot is covered by a "Dive Pre-Dive" decal (not shown).

Screw Driver Slot

Tracking
Cam Lobe

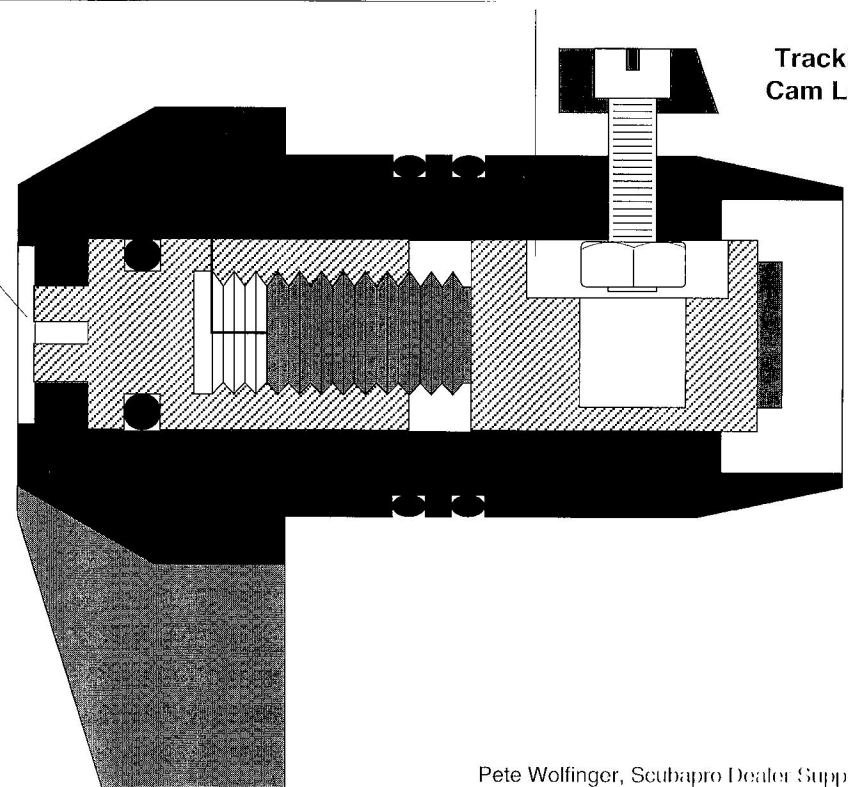

Figure #4

*SCUBAPRO™ Polar Second Stage
Full Cutaway*

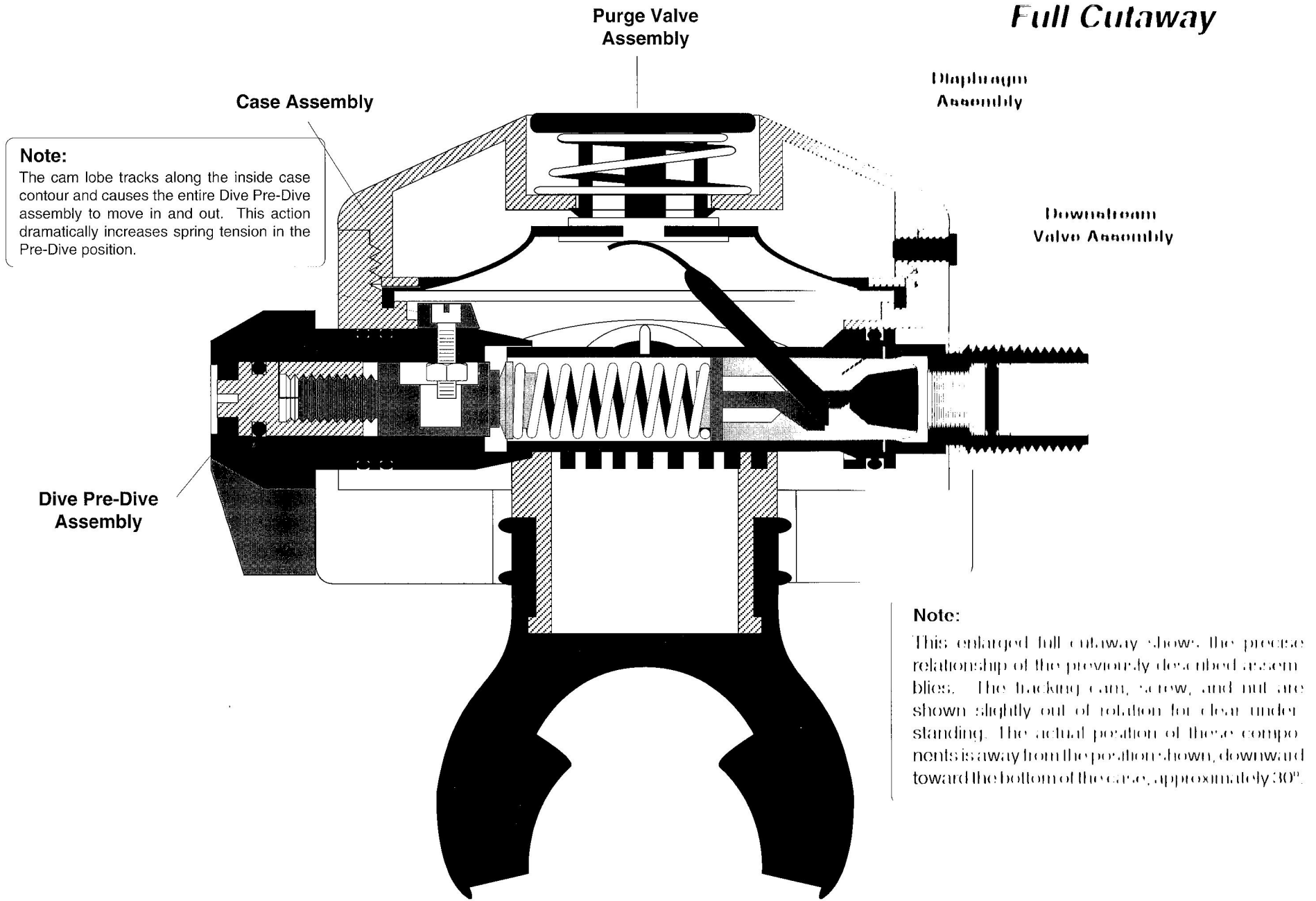
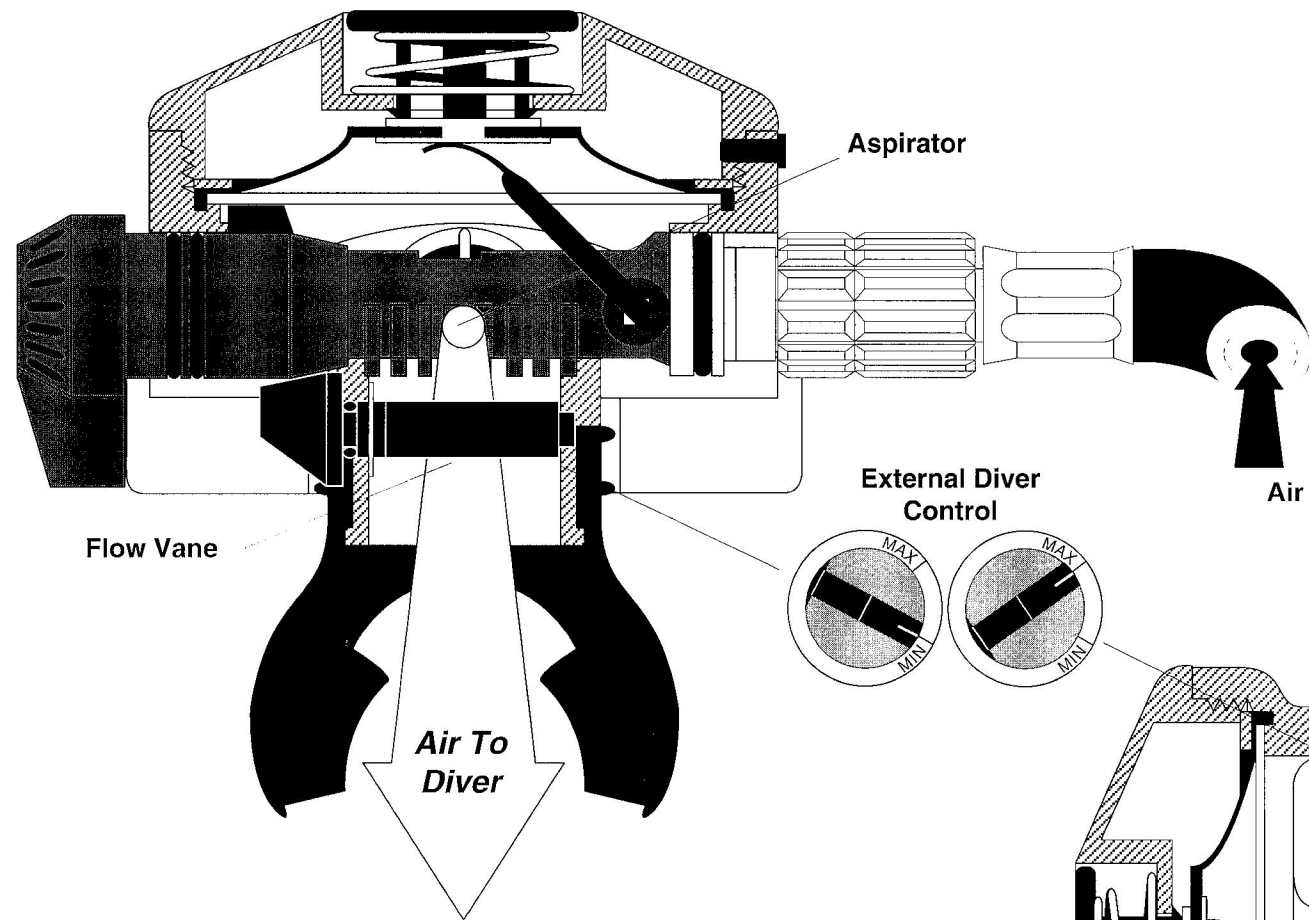

Figure #5



SCUBAPRO[®] Polar Second Stage VIVA

Venturi Initiated Vacuum Assist

Note:

The Polar takes full advantage of internal air flow dynamics to produce smooth comfortable air delivery that can be adjusted externally to the needs of the diver.

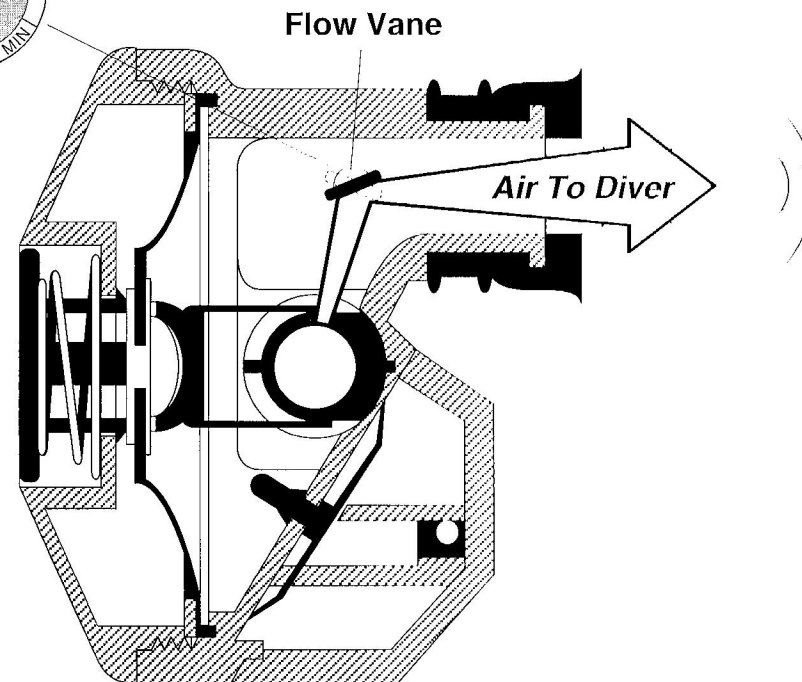
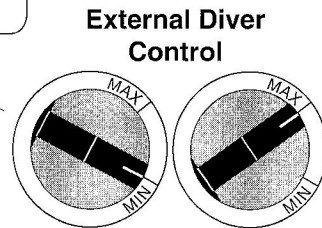

How VIVA Works:

Scubapro VIVA adds exceptional comfort to each breath by utilizing the velocity of the flowing air to reduce the inhalation effort required to keep the air moving. This is accomplished by focusing the air stream through an aspirator directly to a deflection vane which can be rotated to change its angle. When the vane is adjusted to maximum, as shown in the illustration to the right, the high speed air stream is focused directly out through the mouthpiece maintaining most of its original speed. When the vane is rotated downward, the air must bounce several times before exiting, creating friction and reducing the velocity. The amount of vacuum created behind the air stream, inside the regulator case, is directly proportional to the speed of the air. This vacuum pulls inward on the diaphragm, depressing the lever, and reducing the inhalation effort required to maintain flow. The amount of assist can be precisely tuned to suit the needs of the diver and diving conditions.

Figure #6

SCUBAPRO® Polar Second Stage Dive Pre-Dive Control

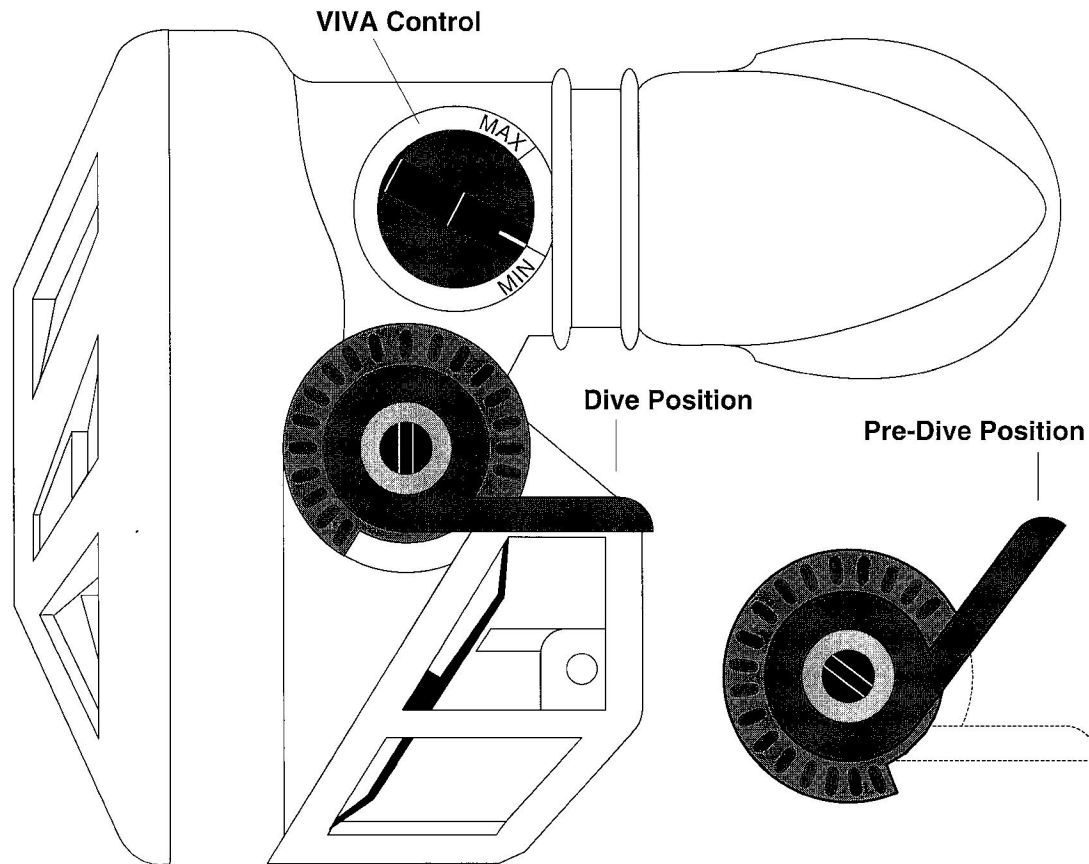

Note:

The above illustration shows the two positions of the external Dive Pre-Dive control. This lever is generally considered to be in one position or the other and it is not designed to maintain an adjustment in an intermediate position. The handle protrudes well beyond the exhaust tee and is easy to operate even with heavy gloves. The relative position of the VIVA control is also indicated.

SCUBAPRO® Polar Second Stage Features & Benefits Summary

Exclusive Features:

- Cold water service utilizing technopolymer materials in critical components (air barrel & poppet).
- Lightweight (183 gr.) almost neutral in the water.
- Delrin orifice will not corrode to brass housing.
- EPDM seat material produces exceptional performance in all temperatures.
- Dual adjustment design allows precise spring tension control without altering lever height.
- Dive Pre-Dive control

Standard Features:

- Classic downstream valve for reliable performance and minimal service.
- High flow exhaust valve.
- VIVA, Venturi Initiated Vacuum Assist
- Tough nylon case.
- Limited Lifetime Warranty.

Figure #7

SCUBAPRO® Polar Second Stage Adjustment Tips & Procedures

General Comments:

The Polar valve mechanism is an escape from traditional design and will require a comprehensive understanding of how the valve functions in order to adjust it properly. The primary difference resides in the fact that spring tension can be altered from two different locations, the orifice and the split adjusting nut and pad assembly.

This dual adjusting feature has major advantages in regard to controlling lever height. In most regulators, both the spring tension and lever height are set by adjusting the orifice. The position of the orifice is normally set at the point where it seals against the intermediate pressure and the lever height is seldom considered. This procedure will work 99% of the time because of today's consistent manufacturing tolerances in regard to the angle of the lever tabs. Occasionally, a regulator that has been adjusted in this manner will produce a higher than normal cracking effort when the final Magnehelic checks are made. This inconsistency can often be traced to improper (low) lever height. The Polar's dual adjustment design permits the skilled technician to overcome minor lever variations and precisely adjust the unit to spec. Making the final adjustments from the outboard end also precludes any possibility of damaging the seat resulting from turning the orifice while it is in contact with the seat.

The goal is to set the valve at the optimum spring tension and maintain correct lever height. The following procedure will help you to understand the best sequence in accomplishing this end result.

Preliminary Assembly Setup:

When you are assembling the Polar, there are a few preliminary setups that will get the components close to the proper position and eliminate major adjustments. The final adjustments will, of course, be made with the air turned on.

- Run the orifice into the brass housing until it hits bottom (clockwise) and then back it out (counterclockwise) approximately $1\frac{3}{4}$ turns.
- Separate the split adjusting nut and the adjusting pad so that 2-3 threads are showing between the two parts. This location will possibly vary to accommodate starting the cam screw in the final assembly.
- Do not install the diaphragm and cover until after the lever height has been checked with the air turned on.
- Set the Dive Pre-Dive lever to the Dive position.
- Set the VIVA control to MIN.

For "Air On Adjustments" see figure #8.

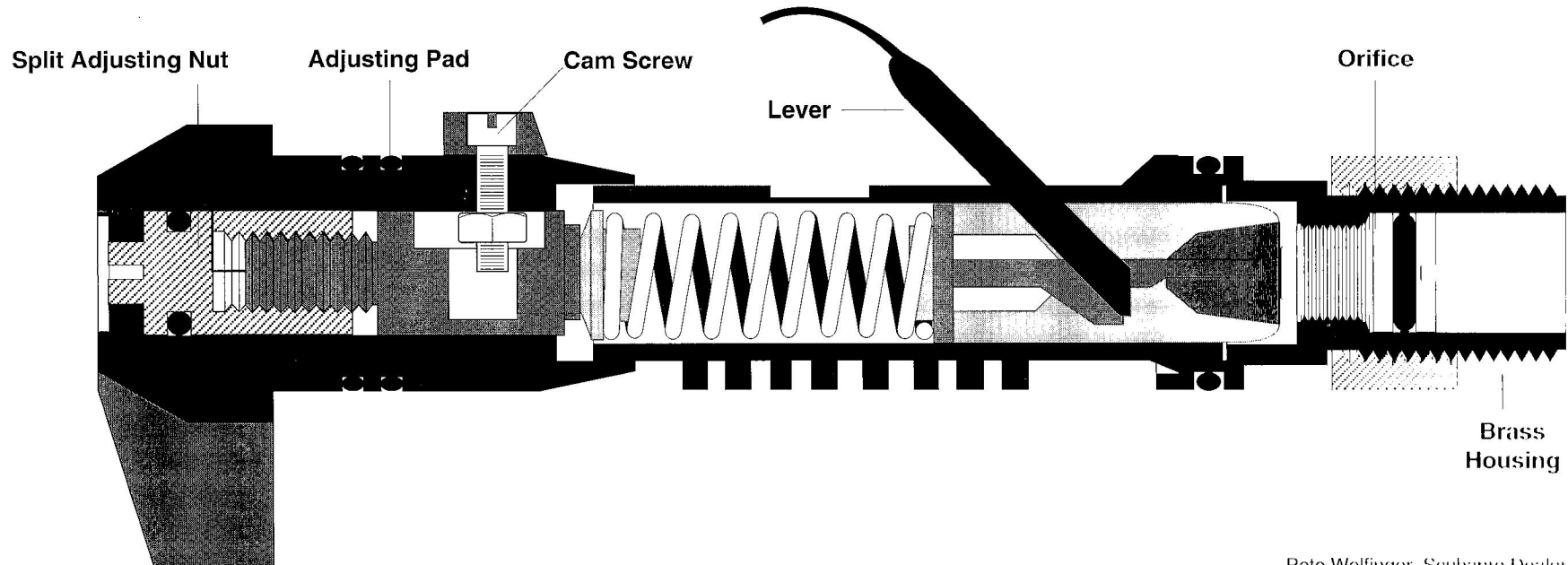

Figure #8

SCUBAPRO® Polar Second Stage Air On Adjustments

Air On, Orifice Adjustments:

1. Install the pneumatic adjusting tool to the Polar second stage.
2. Install the hose from the first stage to the adjusting tool.
3. Before turning the air on, index the adjusting tool bit with the orifice slot (see note, bottom center).
4. Turn the air on gently. The adjusting tool knob will pop outward in response to the air pressure.
5. If an audible air leak is heard, push inward firmly on the adjusting tool knob and rotate the orifice clockwise* (inward) until the leak stops.
6. If no audible leak is heard, rotate the orifice counterclockwise (outward) until a leak is present and then stop the leak by reversing the orifice rotation.
7. Purge the second stage several times to insure the leak does not reoccur.
8. Check the lever height by slightly depressing the purge button. The slightest movement should cause the valve to leak air.
9. Adjust the lever height, if necessary, by turning the orifice with the pneumatic adjusting tool. (Rotating the orifice clockwise lowers the lever and counterclockwise raises the lever.)
10. If adjusting the lever causes the valve to leak, turn the split nut counterclockwise until the air leak stops. It is advisable to go approximately an 1/8 of a turn further than the point where the air leak stops. This slight "de-tune" will allow the soft rubber seat to take a set without causing post adjustment leaks.
11. Purge the second stage several times to be sure the poppet seals without leaking.
12. Check the inhalation and exhalation effort using the Magnehelic** gauge. If the Magnehelic readings for inhalation effort are higher or lower than the standards (figure #10), consult the troubleshooting guide (figure #11).

Note: For a complete description of the above tests and procedures consult Chapter 7, "Second Stage Adjustment Fundamentals".

* All references to clock rotation are described as if you were facing the part.

** Magnehelic - Registered trademark of Dwyer Instruments, Inc.

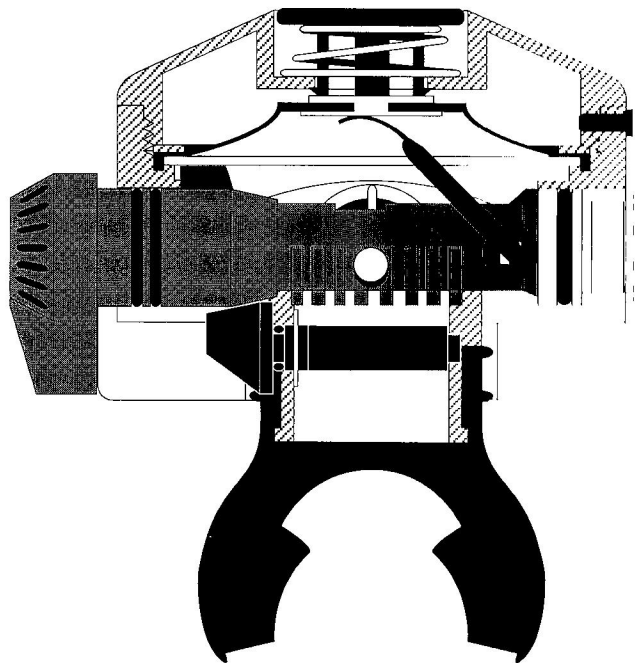

Intermediate
Pressure
Range

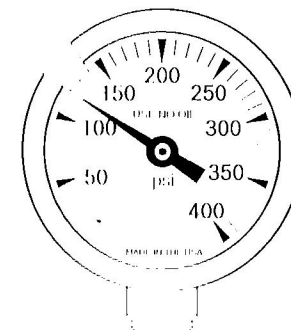

SCUBAPRO
SPECIAL TOOLS

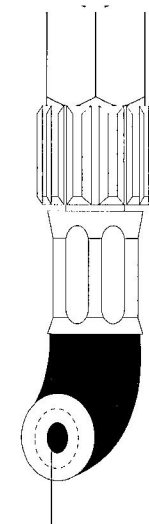

Air From First Stage

Indexing the Adjusting Tool:

The easiest way to index the adjusting tool bit and the orifice slot is to locate the slot before you turn the air on. When air pressure is present, the adjusting tool stem and knob are forced outward and firm inward hand pressure is required to overcome the force of the air. Trying to mate the bit and slot while pushing in on the knob can be difficult. If the two are indexed prior to turning the air on, the pressure will drive the stem and knob "straight outward" without altering the rotational alignment. By pushing "straight inward", the bit and slot will index perfectly and any rotation of the adjusting tool knob will also turn the orifice.

Figure #9

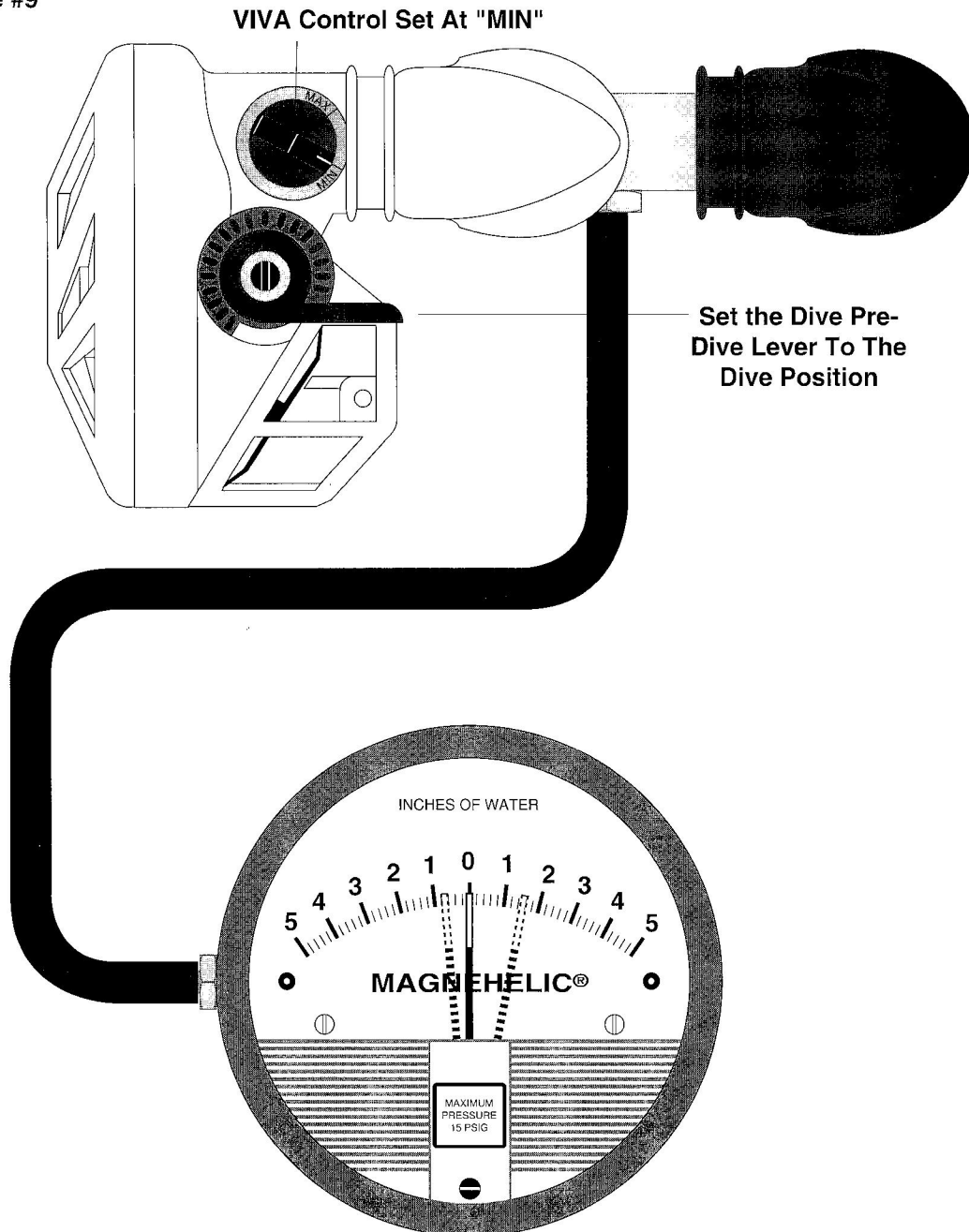

SCUBAPRO[®] Polar Second Stage Magnehelic Gauge Checks

Magnehelic Gauge Checks:

1. Install the Magnehelic[®] gauge to the second stage as shown on the left
2. Set the Dive Pre Dive lever to the Dive position and set the VIVA control to the "MIN" position
3. Turn the air on gently
4. "Inhale" through the Magnehelic mouthpiece extension "as gently as possible" while watching the Magnehelic needle move to the right. Observe the pressure reading on the gauge when the second stage cracks open and delivers air. Take several readings to insure accuracy.
5. "Blow" through the Magnehelic mouthpiece extension "as gently as possible" while watching the needle move to the left. Observe the reading on the gauge when the exhaust valve releases and passes air. Take several readings to insure accuracy.

Polar Standards:

Inhalation Range: 1.2-1.5 Inches Of Water

Exhalation Range: .4-.6 Inches Of Water

Note: For a complete description of the above test procedure consult Chapter 7, "Second Stage Adjustment Fundamentals."

Figure #10

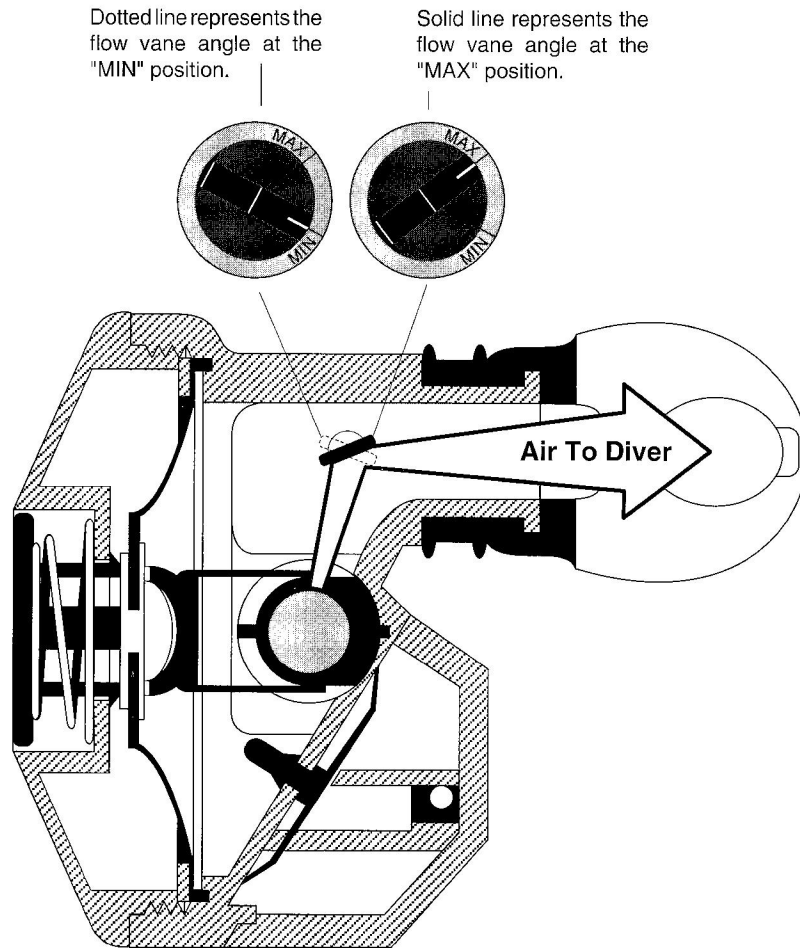

SCUBAPRO® Polar Second Stage VIVA Checks

VIVA Checks:

1. Remove the Magnehelic gauge and connect the first stage hose directly to the second stage. Be sure to firmly tension the hose connection.
2. Set the adjusting knob at the outward most position against the stop clip.
3. Turn the air on.
4. Set the VIVA control at the "MIN" position and fully depress the purge button. The valve should stop immediately upon release of the purge button.
5. Set the VIVA control at the "MAX" position and fully depress the purge button. The valve should remain open and the air should "free flow" when the purge button is released. To stop the air flow, place your thumb over the mouthpiece opening.
6. Check the VIVA override position (see note below).

VIVA Override Position:

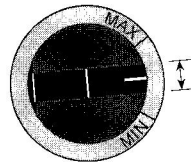

The point where the VIVA begins to override the resistance of the valve should be between the limits shown in the illustration to the left. This point is located by gradually increasing the VIVA effect and purging the second stage at each interval. At this position, the valve will try to free flow but will shut off by itself after a brief override. It is always advisable not to set the VIVA beyond this level when the second stage is returned to your customer. Take a few minutes and demonstrate this dynamic air flow assist. It provides exceptional breathing comfort when properly used.

Figure #11

SCUBAPRO® Polar Second Stage Trouble Shooting Guide

Continuous slow leak from second stage.

- | | |
|------------------------------------|------------------------------------|
| Cause: | Remedy: |
| • Bad rubber seat | • Replace seat |
| • Nicked or damaged orifice | • Replace orifice |
| • High Intermediate pressure | • See first stage trouble shooting |
| • Low spring tension | • Readjust split nut or orifice |

Note: Slow air leaks can usually be traced to the seating compatibility of the orifice & rubber seat. Be sure that the old seat is always replaced when the regulator is serviced. The groove in the old seat may not match with the orifice if you attempt to reuse it. The soft neoprene material can also be easily cut or deeply grooved if repeated orifice adjustments are made.

Inhalation effort is "higher" than specification.

- | | |
|---------------------------------------|--|
| Cause: | Remedy: |
| • Lever adjusted too low | • Raise lever by retracting orifice & readjust split nut |
| • Improper split nut adjustment | • See adjustment steps 5, 6, & 7 |
| • Low intermediate pressure | • See first stage trouble shooting |
| • Low tank pressure | • Fill or replace tank |

Note: Provided that the adjustment procedure has been followed, hard breathing symptoms can often be corrected by proper cleaning and lubrication. If you are attempting to adjust a dirty or dry second stage, you may need to overhaul, clean, and lubricate the unit before the inhalation effort can be improved.

Inhalation effort is "lower" than specification.

- | | |
|--------------------------------------|--------------------------------------|
| Cause: | Remedy: |
| • Orifice is retracted too far | • Reset orifice & readjust split nut |

Note: It is seldom considered a problem when a regulator breathes too easily, but downstream valves can become "unstable" if they are adjusted below 1.0" H₂O. Low cracking efforts also dramatically affect the VIVA range.

Violent free flow from second stage.

- | | |
|--|---|
| Cause: | Remedy: |
| • VIVA adjusted beyond the override position | • Readjust VIVA control |
| • High intermediate pressure | • See first stage trouble shooting |
| • Poppet or lever stuck in the open position | • Check for obstructions or damaged valve parts |

Note: The preceding causes and remedies are based upon proper assembly of the poppet, lever, and spring. If the poppet is installed in a rotated position and hits the lever tabs preventing contact with the orifice, a violent free flow will occur as soon as the air is turned on.

VIVA does not override demand effort at the MAX setting.

- | | |
|--|--|
| Cause: | Remedy: |
| • Valve adjusted too stiff | • Readjust valve beginning with orifice and lever position |
| • Lever adjusted too low | • Raise lever by retracting orifice & readjust split nut |
| • Lever in the "Pre-Dive" position | • Reset to "Dive" position |

Note: When the regulator is properly adjusted the VIVA will override the demand effort and cause the second stage to free flow at maximum capacity. This should occur at approximately the mid point of the VIVA range.